



ORIENT

Photo coupler

Product Data Sheet

Part Number: ORPC-817-(GK)

Customer: _____

Date: _____

SHENZHEN ORIENT COMPONENTS CO ., LTD

Block A3rd Floor No.4 Building, Tian'an Cyber Park, Huangge Rd, LongGang Dist, Shenzhen, GD

TEL: 0755-29681817

FAX: 0755-29681200

www.orient-opto.com

1. Features

- (1) Current transfer ratio (CTR : MIN. 50% at $I_F = 5\text{mA}$, $V_{CE} = 5\text{V}$)
- (2) High input-output isolation voltage ($V_{iso} = 5,000\text{Vrms}$)
- (3) Response time (t_r : TYP. $2.9\mu\text{s}$ at $V_{CE} = 2\text{V}$, $I_C = 2\text{mA}$, $R_L = 100\Omega$)
- (4) ESD pass HBM 8000V/MM 2000V
- (5) Safety approval
 - UL approved (No.E323844)
 - VDE approved(No.40029733)
 - CQC approved (No.CQC09001029446)
 - CE approved (No.AC/0431008)
 - State Grid approved (No.SGCM013420170152)
- (6) In compliance with RoHS, REACH standards
- (7) MSL Class I



2. Description

- (1) ORPC-817-(GK) photo coupler consist of one piece of GaAs emitter and one piece of NPN transistor.
- (2) Packaged in a 4-pin DIP package and available in wide-lead spacing and SMD option.

3. Applications

- (1) Switching power supply
- (2) Ammeter
- (3) Computer
- (4) Instrumental application, measurement machine
- (5) Signal transforming systems
- (6) Imbursement equipments, duplicating machine, automat
- (7) Family-use electric equipments, such as fans

4. Functional Diagram

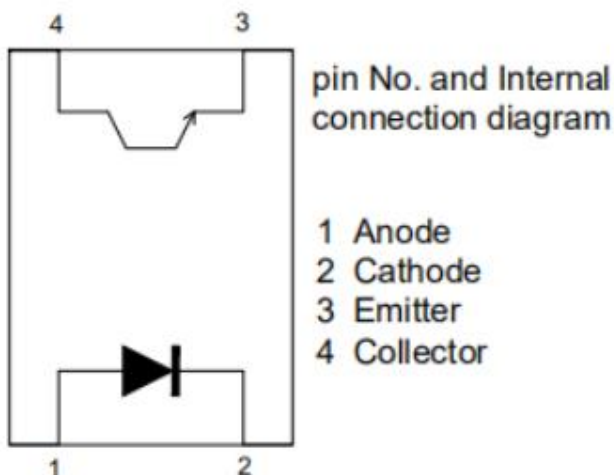

5. Absolute Maximum Ratings at Ta=25°C

| Parameter | | Symbol | Rated Value | Unit |
|--|--|------------|--------------|------|
| Input | Forward Current | I_F | 60 | mA |
| | Peak forward current (100µs pulse, 100Hz frequency) | I_{FP} | 1 | A |
| | Reverse Voltage | V_R | 6 | V |
| | Input Power | P_I | 70 | mW |
| Output | Collector and emitter Voltage | V_{CEO} | 80 | V |
| | Emitter and collector Voltage | V_{ECO} | 7 | |
| | Collector Current | I_C | 50 | mA |
| | Output Power | P_O | 150 | mW |
| Total Consume Power | | P_{tot} | 200 | mW |
| *1 Isolation Voltage | | V_{iso} | 5,000 | Vrms |
| Max Insulation Voltage (Insulating oil test) | | V_{IOTM} | 10,000 | V |
| Rated Impulse Insulation Voltage | | V_{IORM} | 630 | V |
| Operation Temperature | | T_{opr} | -55 to + 125 | °C |
| Storage Temperature | | T_{stg} | -55 to + 150 | |
| *2 Soldering Temperature | | T_{sol} | 260 | |

*1.AC For 1 Minute, R.H. = 40 ~ 60%

Isolation voltage shall be measured using the following method.

- (1) Short between anode and cathode on the primary side and between collector and emitter on the secondary side.
- (2) The isolation voltage tester with zero-cross circuit shall be used.
- (3) The waveform of applied voltage shall be a sine wave.

*2. Soldering time is 10 seconds

6. Electro-Optical Characteristics (Ta=25°C unless specified otherwise)

| Parameter | | Symbol | Min | Typ.* | Max | Unit | Condition |
|-------------------------------------|---|---------------|--------------------|--------------------|---------------|---------------|--|
| Input | Forward Voltage | V_F | --- | 1.2 | 1.4 | V | $I_F=20\text{mA}$ |
| | Reverse Current | I_R | --- | --- | 5 | μA | $V_R=5\text{V}$ |
| | Input Capacitance | C_t | --- | 10 | 200 | pF | $V=0, f=1\text{MHz}$ |
| Output | Dark Current | I_{CEO} | --- | --- | 100 | nA | $V_{CE}=20\text{V}$ $I_F=0\text{mA}$ |
| | Collector and Emitter attenuation Voltage | BV_{CEO} | 80 | --- | --- | V | $I_C=0.1\text{mA}$ $I_F=0\text{mA}$ |
| | Emitter and Collector attenuation Voltage | BV_{ECO} | 7 | --- | --- | V | $I_E=0.1\text{mA}$ $I_F=0\text{mA}$ |
| Transforming Characteristics | *1 Current transfer ratio | CTR | 50 | --- | 600 | % | $I_F=5\text{mA}$ $V_{CE}=5\text{V}$ |
| | Collector Current | I_C | 2.5 | --- | 30 | mA | $I_F=5\text{mA}$ $V_{CE}=5\text{V}$ |
| | Collector and Emitter Saturation Voltage | $V_{CE(sat)}$ | --- | 0.1 | 0.2 | V | $I_F=20\text{mA}$ $I_C=1\text{mA}$ |
| | Isolation Impedance | R_{iso} | 5×10^{10} | 1×10^{12} | --- | Ω | DC500V 40~60%R.H. |
| | Floating Capacitance | C_f | --- | 0.4 | 1.0 | pF | $V=0, f=1\text{MHz}$ |
| | Cut-off Frequency | f_c | --- | 260 | --- | kHz | $V_{CE}=5\text{V}$ $I_C=2\text{mA}$ $R_L=100\Omega, -3\text{dB}$ |
| | Rise Time | t_r | --- | 2.9 | 10 | μs | $V_{CC}=2\text{V}$ $I_C=2\text{mA}$ $R_L=100\Omega$ |
| | Fall Time | t_f | --- | 4.5 | 10 | μs | |
| | Turn-on Time | t_{on} | --- | 6.3 | 10 | μs | |
| Turn-off Time | t_{off} | --- | 7.1 | 10 | μs | | |

*1 Current Conversion Ratio = $I_C / I_F \times 100\%$, CTR Tolerance: $\pm 3\%$.

7. Rank Table of Current Transfer Ratio

| CTR Rank | Min. | Max. | Condition | Unit |
|----------|------|------|---------------------------------------|------|
| L | 50 | 100 | $I_F=5mA, V_{CE}=5V, T_a=25^{\circ}C$ | % |
| A | 80 | 160 | | |
| B | 130 | 260 | | |
| C | 200 | 400 | | |
| D | 300 | 600 | | |

| CTR Rank | Min. | Max. | Condition | Unit |
|----------|------|------|---|------|
| A5 | 4 | 20 | $I_F=0.1mA, V_{CE}=5V, T_a=25^{\circ}C$ | % |
| B5 | 6.5 | 34 | | |
| C5 | 10 | 52 | | |
| D5 | 15 | 78 | | |
| A6 | 24 | 72 | $I_F=0.5mA, V_{CE}=5V, T_a=25^{\circ}C$ | |
| B6 | 40 | 120 | | |
| C6 | 70 | 140 | | |
| D6 | 90 | 270 | | |
| A7 | 40 | 105 | $I_F=1mA, V_{CE}=5V, T_a=25^{\circ}C$ | |
| B7 | 65 | 170 | | |
| C7 | 100 | 260 | | |
| D7 | 150 | 390 | | |



8. Order Information

Part Number

ORPC-817XT-V-W-Y-Z-(GK)

Note

X = Lead form option (S, M or none)

T = CTR Rank (L, A, B, C, D, A5, B5, C5...)

V = Tape and reel option (TP, TP1 or none).

W = Lead frame (F:Iron, C:copper)

Y = 'V' code for VDE safety (This options is not necessary).

Z = 'G' code for Halogen free (Copper for HF only).

GK = Field Code.

* VDE Code can be selected.

| Option | Description | Packing quantity |
|--------|--|---------------------|
| None | Standard DIP-4 | 100 units per tube |
| M | Wide lead bend (0.4 inch spacing) | 100 units per tube |
| S(TP) | Surface mount lead form (low profile) + TP tape & reel option | 2000 units per reel |
| S(TP1) | Surface mount lead form (low profile) + TP1 tape & reel option | 2000 units per reel |

9. Naming Rule

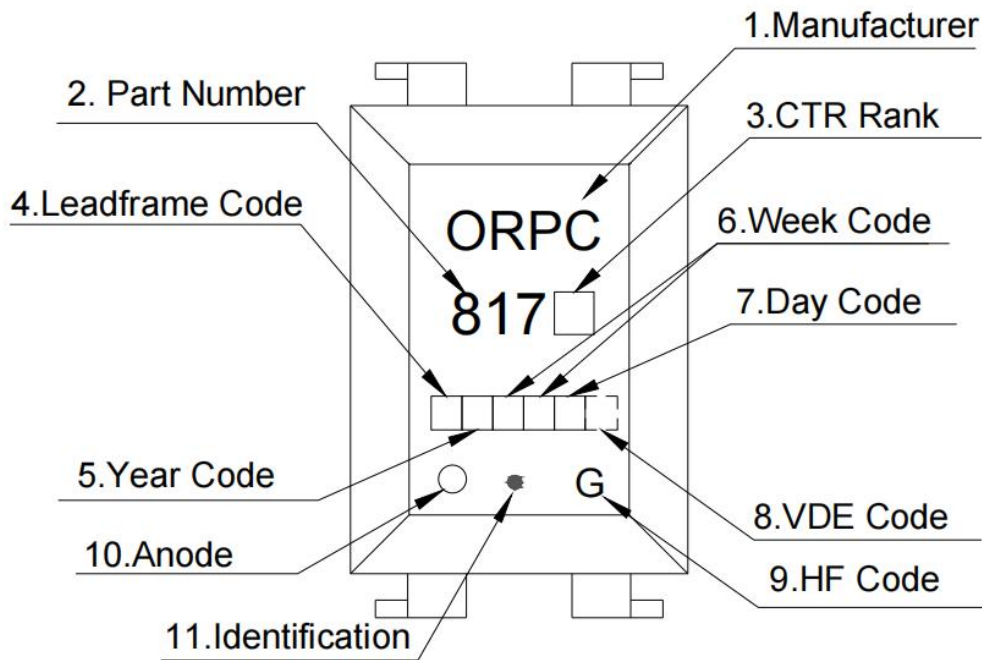

- (1) ORIENT PHOTOCOUPLER.
- (2) 817 denotes Device Part Number.
- (3) denotes Rank Code.(Number not mark, L,A,B,C or D only)
(For example “C6” mark “C” only)
- (4) denotes Lead Frame Code.
- (5) denotes Year Code.
- (6) denotes Week Code.
- (7) denotes Day Code.
- (8) denotes VDE Code. (Optional)
- (9) denotes HF Code. (Copper for HF only)
- (10) Anode.
- (11) Identification.

* VDE Mark can be selected.

10. Package Dimension (Unit: mm)

(1) ORPC-817

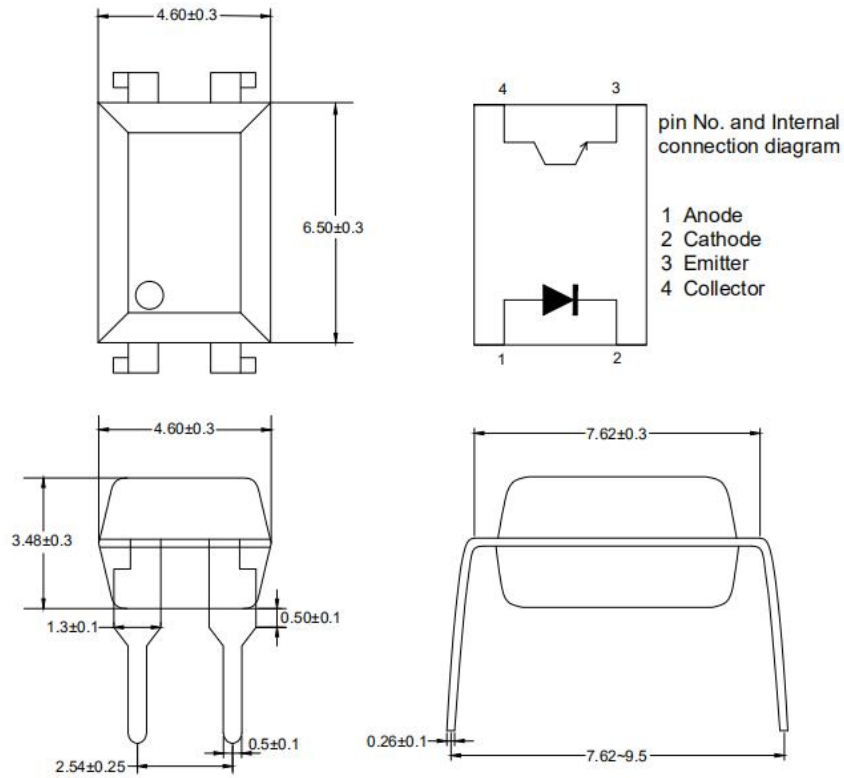

(2) ORPC-817M

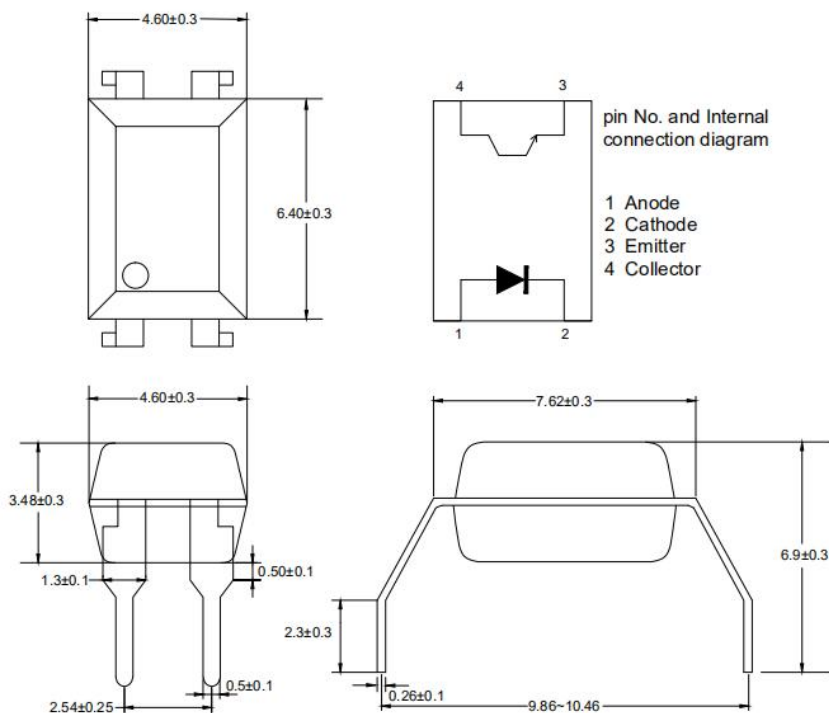

(3) ORPC-817S

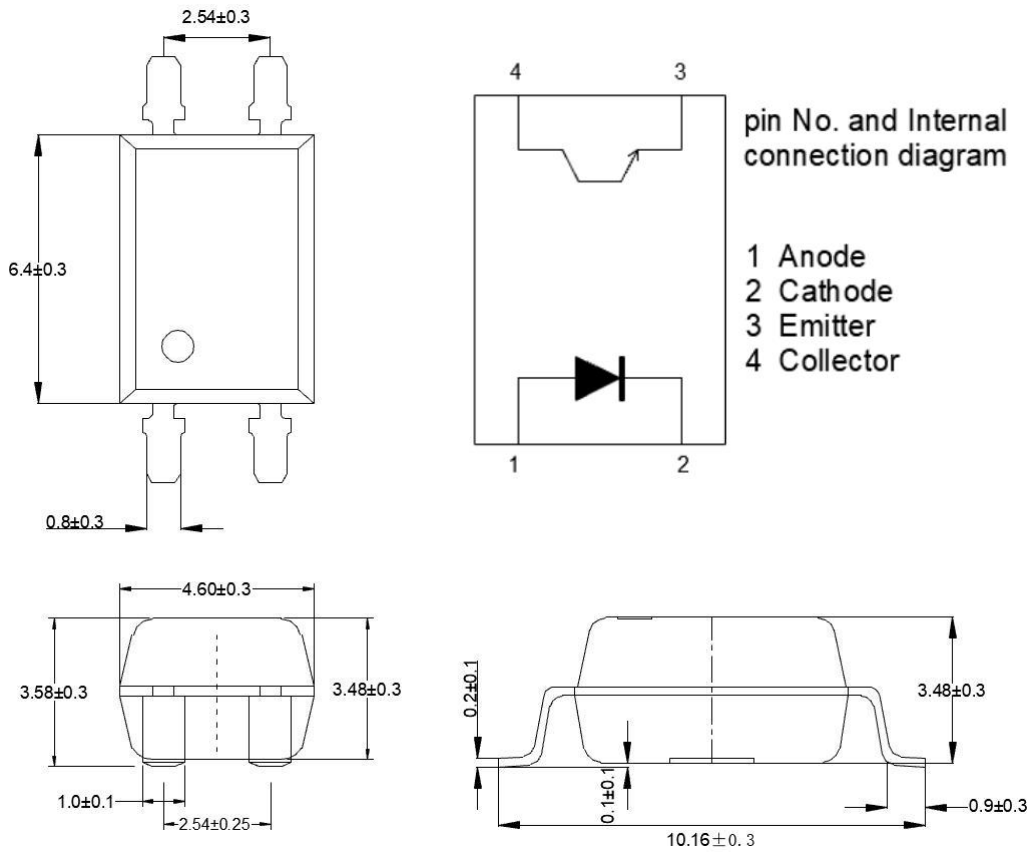

11. Taping Dimensions

(1) ORPC-817S-TP

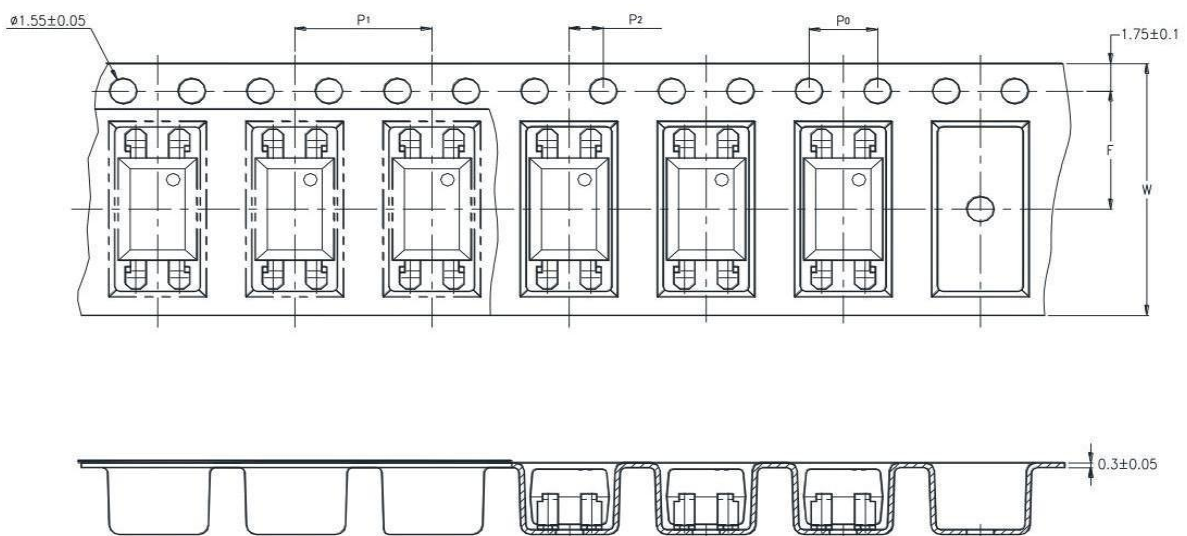

(2)ORPC-817S-TP1

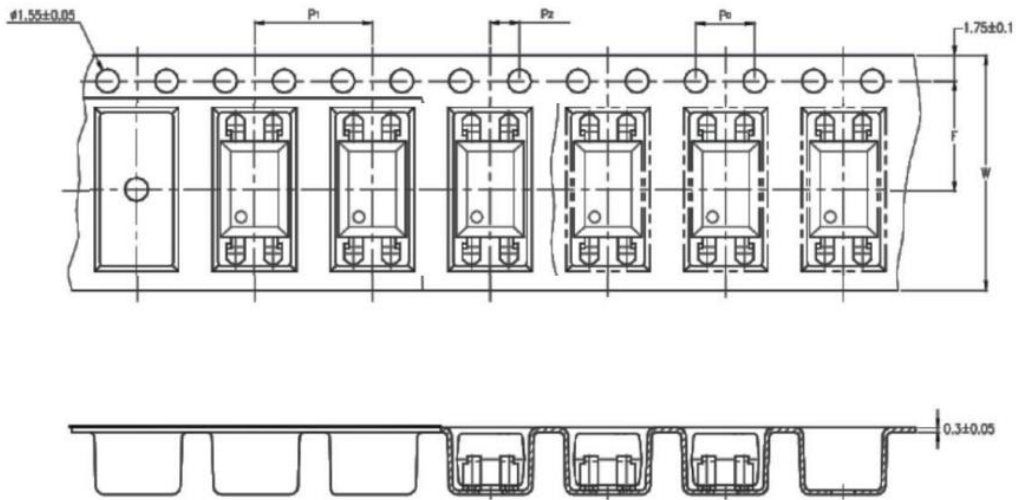

| Description | Symbol | Dimension in mm (inch) |
|--|----------------|------------------------|
| Tape wide | W | 16±0.3 (.63) |
| Pitch of sprocket holes | P ₀ | 4±0.1 (.15) |
| Distance of compartment | F | 7.5±0.1 (.295) |
| | P ₂ | 2±0.1 (.0079) |
| Distance of compartment to compartment | P ₁ | 8±0.1 (.472) |

| | |
|-----------------|--------|
| Package Type | TP/TP1 |
| Quantities(pcs) | 2000 |

12. Recommended Foot Print Patterns (Mount Pad) (Unit: mm)

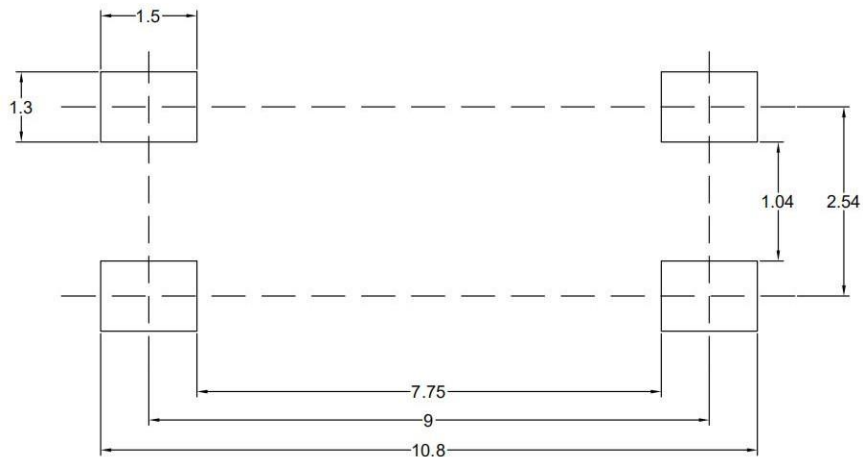

13. Package Dimension

DIP Type



| Packing Information | |
|-----------------------------|---------------|
| Packing type | Tube |
| Qty per Tube | 100pcs |
| Small box (Inner) Dimension | 525*128*60mm |
| Large box (Outer) Dimension | 545*290*335mm |
| The Amount per Inner Box | 5,000pcs |
| The Amount per Outer Box | 50,000pcs |

SOP Type

| Packing Information | |
|-----------------------------|----------------|
| Packing type | Reel type |
| Tape Width | 16mm |
| Qty per Reel | 2,000pcs |
| Small box (inner) Dimension | 345*345*58.5mm |
| Large box (Outer) Dimension | 620x360x360mm |
| Max qty per small box | 4,000pcs |
| Max qty per large box | 40,000pcs |

(2)Packing Label Sample



Material Code : 120PCXXXXXX

P/N: OR-XXXXXX

Lot No. : XXXXXX-XXXXX-TX-X

D/C: XXXX

Qty: XXXX PCS

内箱码

外箱码

“XXXXXXXXXXXXXXXX” (一体机序列码)
Made in China

Note:

1. Material Code :Product ID.
2. P/N :Contents with "Order Information" in the specification.
3. Lot No. :Product data.
4. D/C :Product weeks.
5. Quantity :Packaging quantity.

14. Reliability Test

| NO. | ITEMS | Reliability Testing | | | | |
|-----|----------------------------|---------------------|--|--------------|-----------------------|-------------|
| | | QTY. (Pcs) | Condition | Process | Device | Standard |
| 1 | RSH 耐焊接热 | 22 | 260±5℃ | 10s/3 次 | 锡炉 | JESD22-A106 |
| 2 | HTSL 高温存储 | 77 | 125℃ | 168 hrs | 高温烤箱 测试仪 | JESD22-A103 |
| | | | | 500 hrs | | |
| | | | | 1000 hrs | | |
| 3 | LTSL 低温存储 | 77 | -55℃ | 168 hrs | 低温箱 测试仪 | JESD22-A119 |
| | | | | 500 hrs | | |
| | | | | 1000 hrs | | |
| 4 | TC 温度循环 | 77 | H:125℃ 15min ∫ 5min L:-55℃ 15min | 300 cycle | 冷热冲击机 | JESD22-A104 |
| 5 | TS 温度冲击 | 77 | H:100℃ 5min ∫ 15s L:-40℃ 5min | 300 cycle | 冷热冲击机 | JESD22-A106 |
| 6 | HTOL 高温操作 | 77 | 110℃ IF=10mA Vce=5V | 168 hrs | 高温烤箱 测试仪、老 化电路板 | JESD22-A108 |
| | | | | 500 hrs | | |
| | | | | 1000 hrs | | |
| 7 | ESD-HBM 人体模式 | 22 | ≥8KV 1Cycle | 1次 | ESD静电测 试仪 | JESD22-A114 |
| 8 | SD 可焊性 | 22 | Pb-free 245±5℃ | 5S/1次 | 锡炉 | JESD22-B102 |
| 9 | HTRB 高温反向偏压 | 77 | HTRB @125℃ Vce=80v | 168 hrs | 高温烤箱 , 测试仪 | JESD22-A103 |
| | | | | 500 hrs | | |
| | | | | 1000 hrs | | |
| 10 | H3TRB 温湿度反向偏 压, 寿命试验 | 77 | H3TRB 85℃,85%RH Vce=80v | 168 hrs | 恒温恒湿 机, 测试仪 | JESD22-A101 |
| | | | | 500 hrs | | |
| | | | | 1000 hrs | | |
| 11 | Autoclave 压力锅 | 77 | Ta=121 ℃,100%RH,2atm | 96hrs | 压力锅 | JESD22-A102 |

15. Temperature Profile Of Soldering

(1).IR Reflow soldering (JEDEC-STD-020C compliant)

One time soldering reflow is recommended within the condition of temperature and time profile shown below. Do not solder more than three times.

| Profile item | Conditions |
|--------------------------------------|----------------|
| Preheat | |
| - Temperature Min (T Smin) | 150°C |
| - Temperature Max (T Smax) | 200°C |
| - Time (min to max) (ts) | 90±30 sec |
| Soldering zone | |
| - Temperature (TL) | 217°C |
| - Time (t L) | 60 sec |
| Peak Temperature | 260°C |
| Peak Temperature time | 20 sec |
| Ramp-up rate | 3°C / sec max. |
| Ramp-down rate from peak temperature | 3~6°C / sec |
| Reflow times | ≤3 |

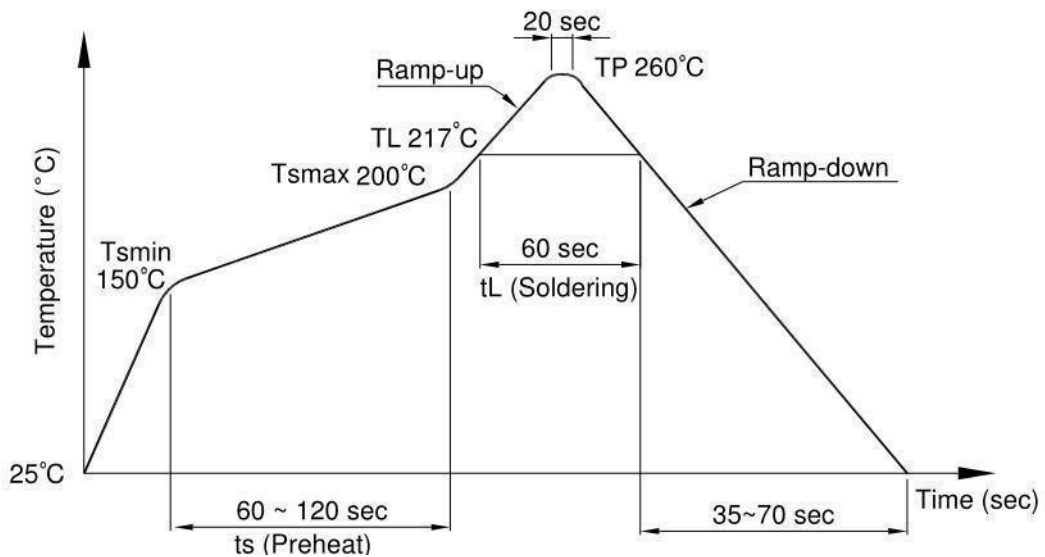

(2).Wave soldering (JEDEC22A111 compliant)

One time soldering is recommended within the condition of temperature.

| | |
|---------------------|--------------|
| Temperature | 260+0/-5°C |
| Time | 10 sec |
| Preheat temperature | 25 to 140°C |
| Preheat time | 30 to 80 sec |

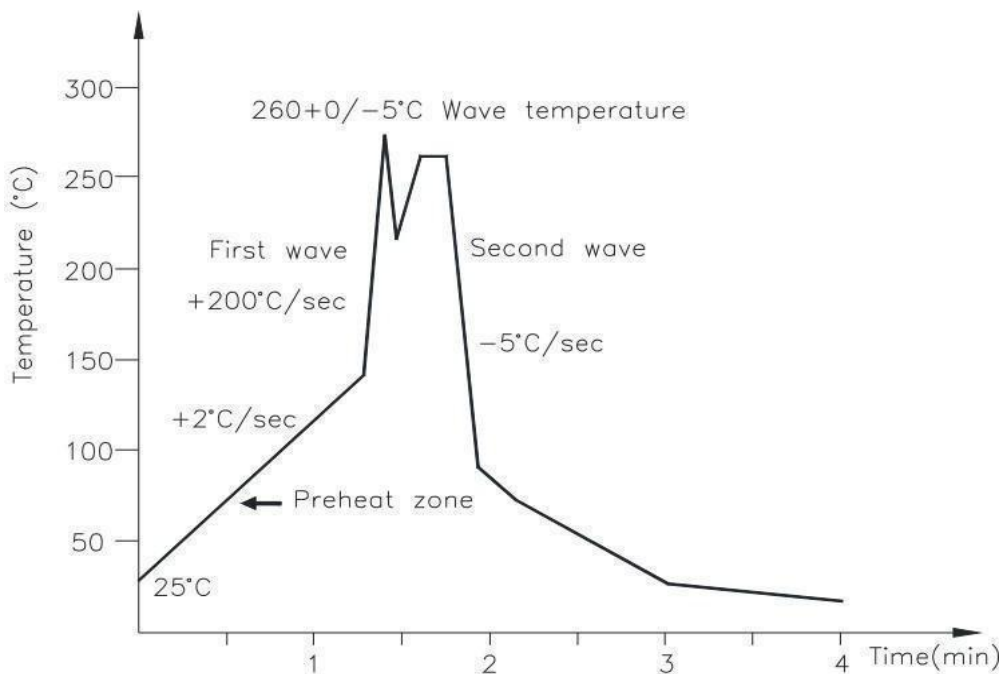

(3).Hand soldering by soldering iron

Allow single lead soldering in every single process. One time soldering is recommended.

| | |
|-------------|------------|
| Temperature | 380+0/-5°C |
| Time | 3 sec max |

16. Characteristics Curves

Fig.1 Forward current vs Ambient temperature

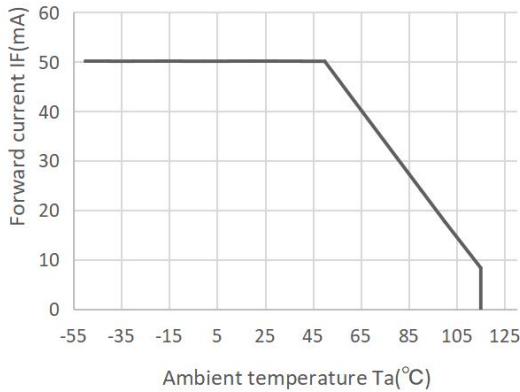

Fig.2 Collector Power Dissipation vs. Ambient temperature

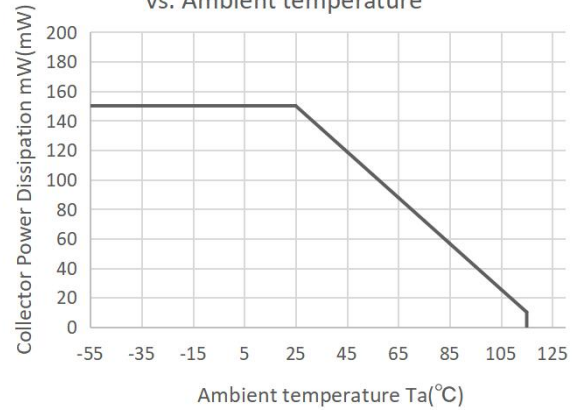

Fig.3 Collector-emitter Saturation Voltage vs. Forward Current

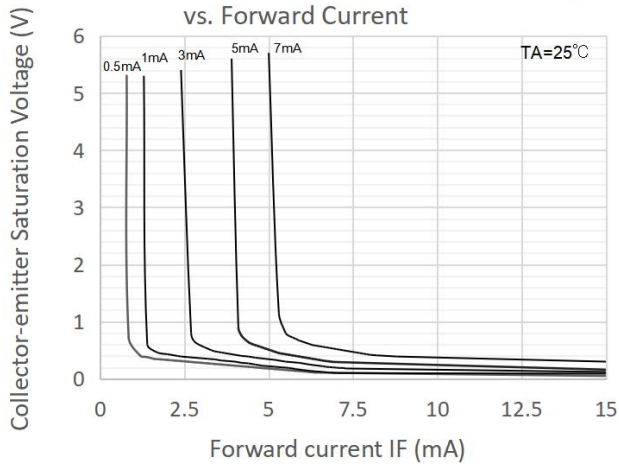

Fig.4 Forward Current vs. Forward Voltage

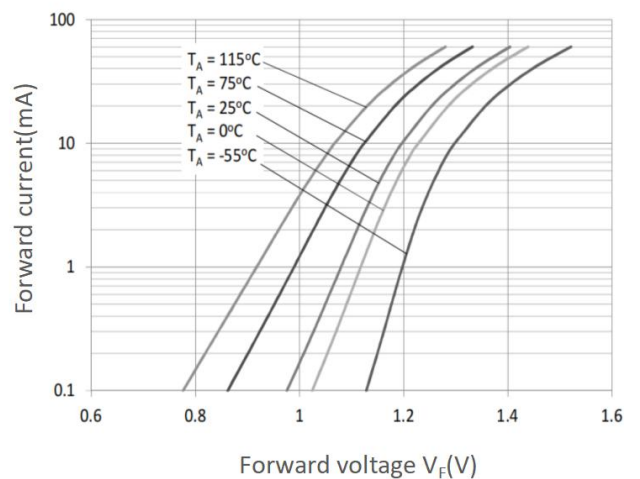

Fig.5 Forward Current vs. Current Transfer Ratio

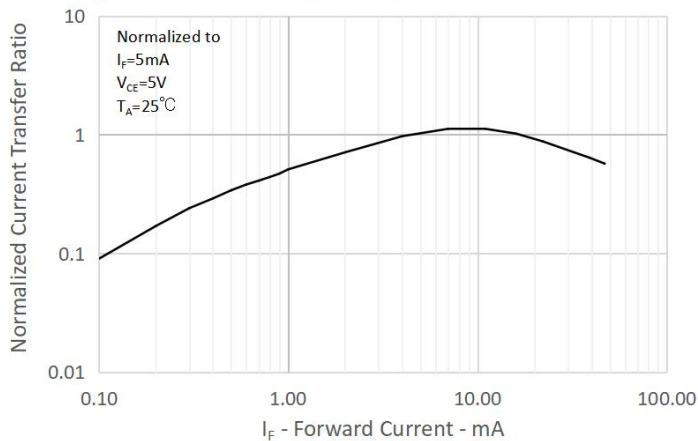

Fig.6 Collector Current vs. Collector-emitter Voltage

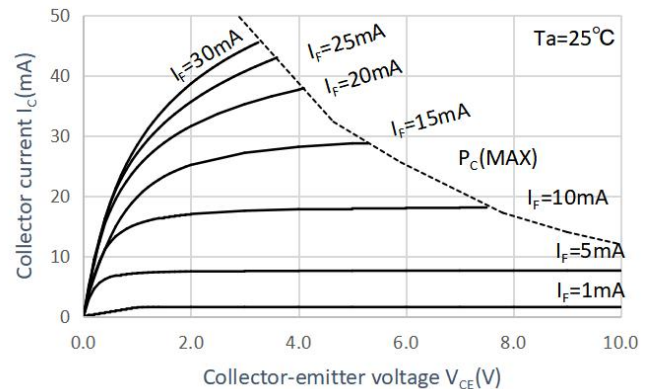

Fig.7 Relative Current Transfer Ratio vs. Ambient Temperature

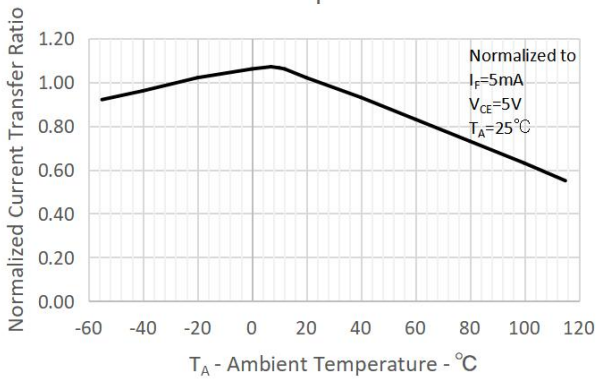

Fig.8 Collector-emitter Saturation Voltage vs. Ambient Temperature

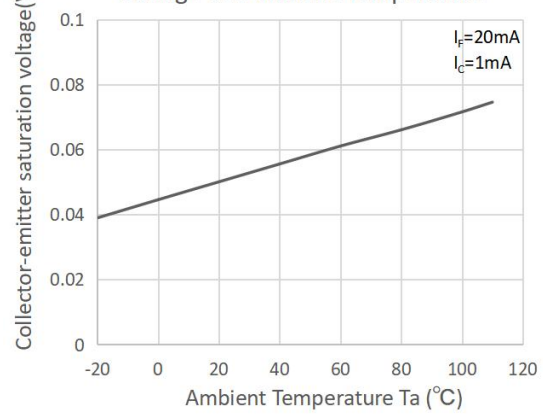

Fig.9 Collector Dark Current vs. Ambient Temperature

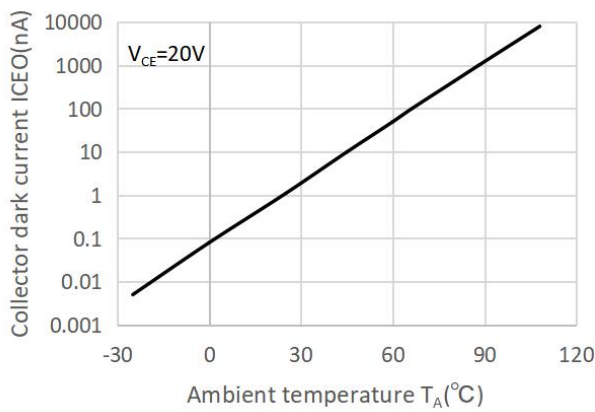

Fig.10 Respinse Time vs. Load Resistance

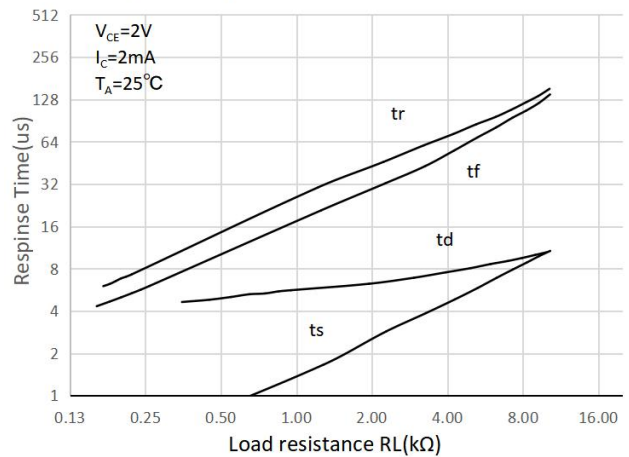
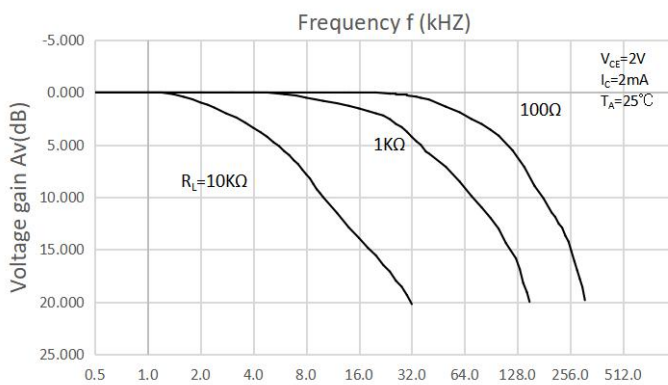
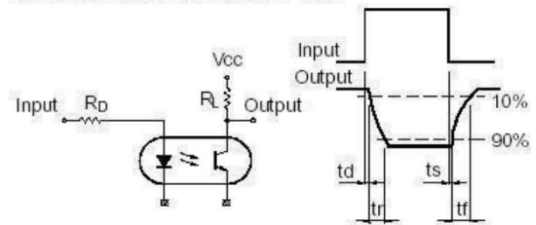

Fig.11 Frequency Response



Test Circuit for Response Time



Test Circuit for Frequency Response

