



# ORIENT

## Photo coupler

### Product Data Sheet

Part Number: ORPC-847

Customer: \_\_\_\_\_

Date: \_\_\_\_\_

**SHENZHEN ORIENT COMPONENTS CO., LTD**

Block A 3rd Floor No.4 Building, Tian'an Cyber Park, Huangge Rd, LongGang Dist, Shenzhen, GD

TEL: 0755-29681816

FAX: 0755-29681200

[www.orient-opto.com](http://www.orient-opto.com)

### 1. Features

- (1) Current conversion ratio
- (2) (Min 50% Working condition  $I_F=5mA$ ,  $V_{CE}=5V$ )
- (3) Insulation Voltage = 5,000Vrms,
- (4) Response Time
- (5) ( $t_r$ : TYP.  $4\mu s$ ;  $t_f$ : TYP.  $5\mu s$  at  $V_{CE}=2V$ ,  $I_C=2mA$ ,  $R_L=100\ \Omega$ )
- (6) ESD pass HBM 8000V/MM 2000V
- (7) Safety approval
  - UL approved (No.E323844)
  - VDE approved (No.40029733)
- (8) In compliance with RoHS, REACH standards
- (9) MSL Class I

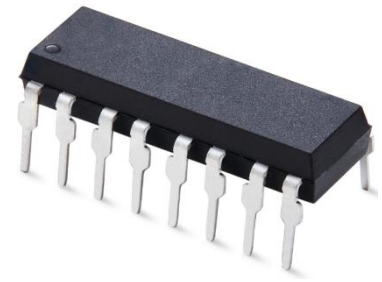

### 2. Instructions

- (1) ORPC-847 series optical coupler consists of four GaAs transmitting tubes and four NPN transistors
- (2) .Pin pitch of ORPC-847 is 2.54mm

### 3. Application Range

- (1) Switching power supply
- (2) Ammeter
- (3) Computer
- (4) Instrumental application, measurement machine
- (5) Imbursement equipments, duplicating machine, automat
- (6) Family-use electric equipments, such as fans
- (7) Signal transforming systems

### 4. Functional Diagram

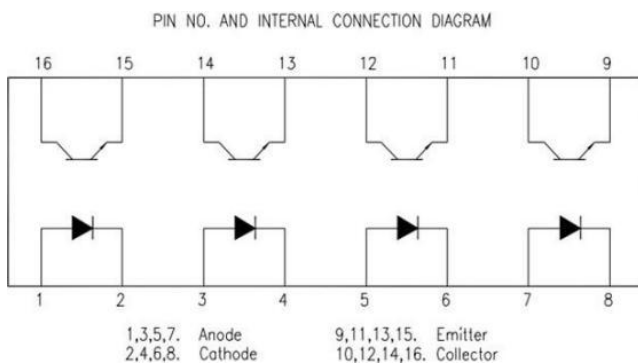

**5. Absolute Maximum Ratings (Ta=25°C)**

Parameter		Symbol	Rated Value	Unit
Input	Forward Current	$I_F$	60	mA
	Peak forward current(1us pulse)	$I_{FP}$	1	A
	Reverse Voltage	$V_R$	6	V
	Consume Power	$P$	70	mW
Output	Collector and emitter Voltage	$V_{CEO}$	80	V
	Emitter and collector Voltage	$V_{ECO}$	7	
	Collector Current	$I_C$	50	mA
	Consume Power	$P_C$	150	mW
Total Consume Power		$P_{tot}$	200	mW
*1 Insulation Voltage		$V_{iso}$	5,000	Vrms
Max Insulation Voltage (Insulating oil test)		$V_{IOTM}$	10,000	V
Rated Impulse Insulation Voltage		$V_{IORM}$	630	V
Working Temperature		$T_{opr}$	-55 to + 110	°C
Deposit Temperature		$T_{stg}$	-55 to + 125	
*2 Soldering Temperature		$T_{sol}$	260	

\*1. AC Test, 1 minute, humidity = 40~60%

Isolation voltage shall be measured using the following method.

(1) Short between anode and cathode on the primary side and between collector and emitter on the secondary side.

(2) The isolation voltage tester with zero-cross circuit shall be used.

(3) The waveform of applied voltage shall be a sine wave.

\*2. soldering time is 10 seconds

**6. Electrical optical characteristics at TA=25°C**

	Parameter	Symbol	Min	Typ.*	Max	Unit	Condition
Input	Forward Voltage	V <sub>F</sub>	---	1.2	1.4	V	I <sub>F</sub> =20mA
	Reverse Current	I <sub>R</sub>	---	---	5	μA	V <sub>R</sub> =5V
	Collector capacitance	C <sub>t</sub>	---	30	250	pF	V=0, f=1KHz
Output	Collector to emitter Current	I <sub>CEO</sub>	---	---	100	nA	V <sub>CE</sub> =20V, I <sub>F</sub> =0mA
	Collector and Emitter attenuation Voltage	BV <sub>CEO</sub>	80	---	---	V	I <sub>C</sub> =0.1mA I <sub>F</sub> =0mA
	Emitter and Collector attenuation Voltage	BV <sub>ECO</sub>	7	---	---	V	I <sub>E</sub> =0.01mA I <sub>F</sub> =0mA
Transforming Characteristics	*1Current conversion ratio	CTR	50	---	600	%	I <sub>F</sub> =5mA V <sub>CE</sub> =5V
	Collector Current	I <sub>C</sub>	2.5	---	30	mA	
	Collector and Emitter Saturation Voltage	V <sub>CE(sat)</sub>	---	0.1	0.2	V	I <sub>F</sub> =20mA I <sub>C</sub> = 1mA
	Insulation Impedance	R <sub>iso</sub>	5×10 <sup>10</sup>	1×10 <sup>12</sup>	---	Ω	DC500V 40~60%R.H.
	capacitance	C <sub>f</sub>	---	0.6	1.0	pF	V=0, f=1MHz
	Transforming Frequency	f <sub>c</sub>	---	80	---	kHz	V <sub>CE</sub> =5V, I <sub>C</sub> =2mA, R <sub>L</sub> =100Ω, -3dB
	Rise time	t <sub>r</sub>	---	4	18	μs	V <sub>CE</sub> =2V, I <sub>C</sub> =2mA, R <sub>L</sub> =100Ω
	Descend Time	t <sub>f</sub>	---	3	18	μs	

\*1 Current Conversion Ratio =  $I_C / I_F \times 100\%$

**7. Rank table of current transfer ratio (CTR)**

Grade Sign	Min (%)	Max (%)
ORPC-847 NO BIN	50	600
ORPC-847BC	130	400
ORPC-847CD	200	600
ORPC-847CD1	300	500

Note: Working condition: I<sub>F</sub>=5mA, V<sub>CE</sub>=5V, T<sub>a</sub>=25°C

## 8. Order Information

### Part Number

**ORPC-847XV-W-Y-Z**

### Note

X = Lead form option (S, M or none)

V = CTR Rank (BC, CD, CD1 or none)

W = Lead frame option (C:copper)

Y = 'V' code for VDE safety (This options is not necessary).

Z = 'G' code for Halogen free. (This options is not necessary).

\* VDE Code can be selected.

Option	Description	Packing quantity
None	Standard DIP-16	24 units per tube
M	Wide lead bend (0.4 inch spacing)	24 units per tube
S	Surface mount lead form (low profile)	24 units per tube

## 9. Naming Rule

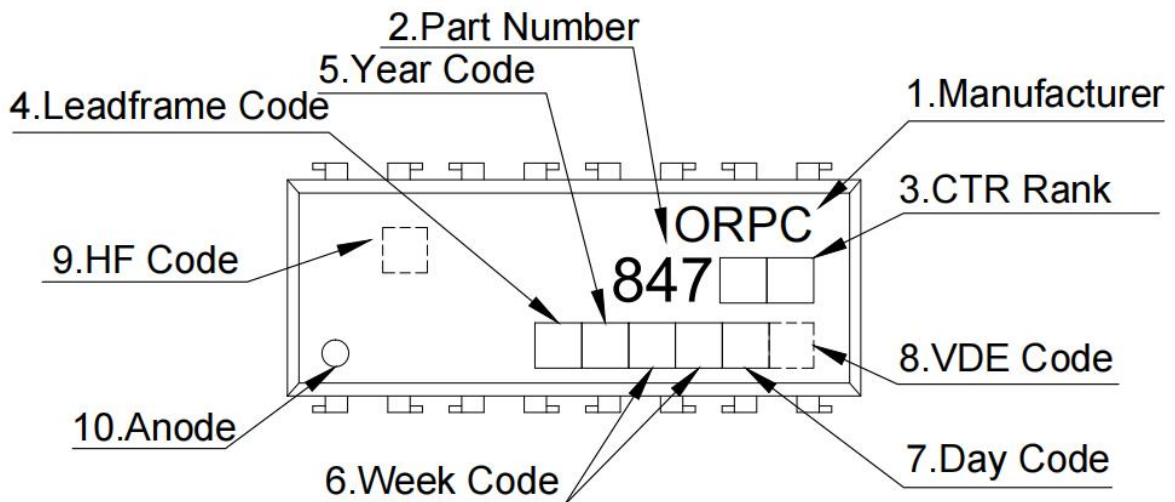

- (1) Manufacturer : ORIENT.
- (2) 847 denotes Part Number.
- (3) CTR Rand  .
- (4) Lead frame Code : 'C' means Copper.
- (5) Year Code  : '1' means '2021' and so on.
- (6) Week Code : 01 means the first week, 02 means the second week and so on.
- (7) Day Code : "A to G" means "Monday to Sunday"
- (8) VDE Code . (Optional)
- (9) HF Code : Halogen Free. (Optional)
- (10) Anode.

\* VDE Mark can be selected.

## 10. Outer Dimension (Unit: mm)

### 1. ORPC-847

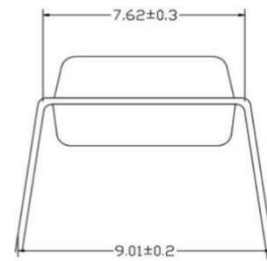
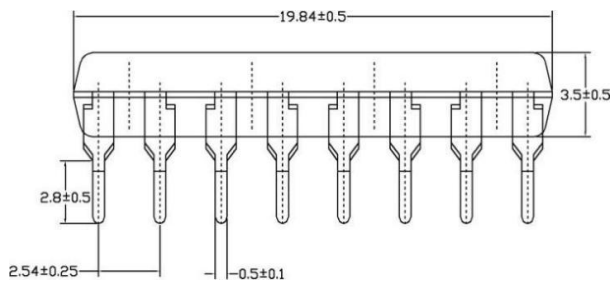
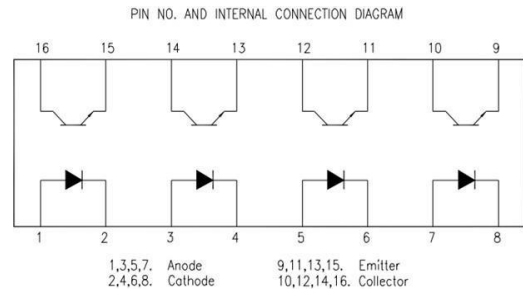
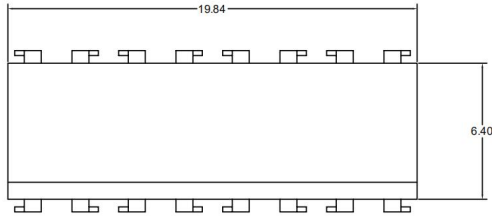

### 2. ORPC-847M

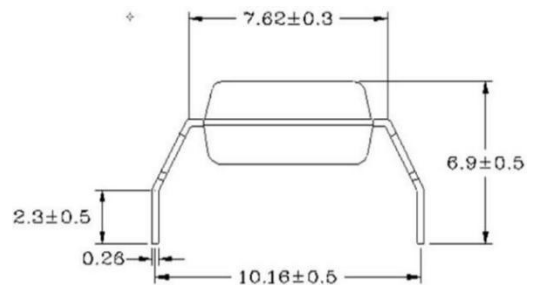
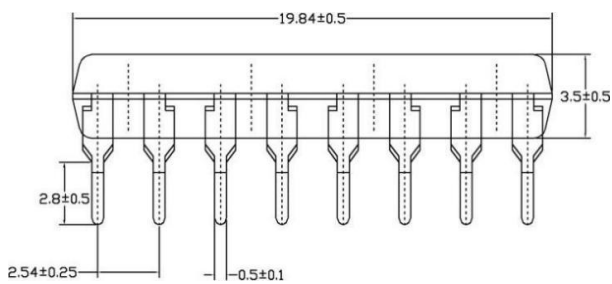
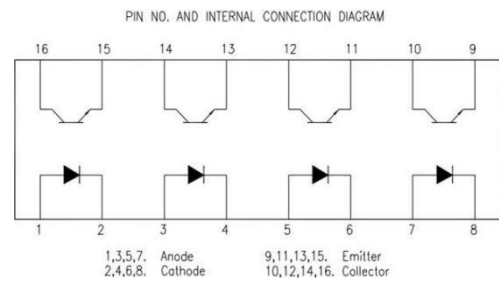
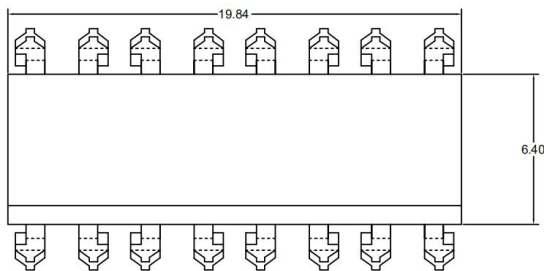

3. ORPC-847S

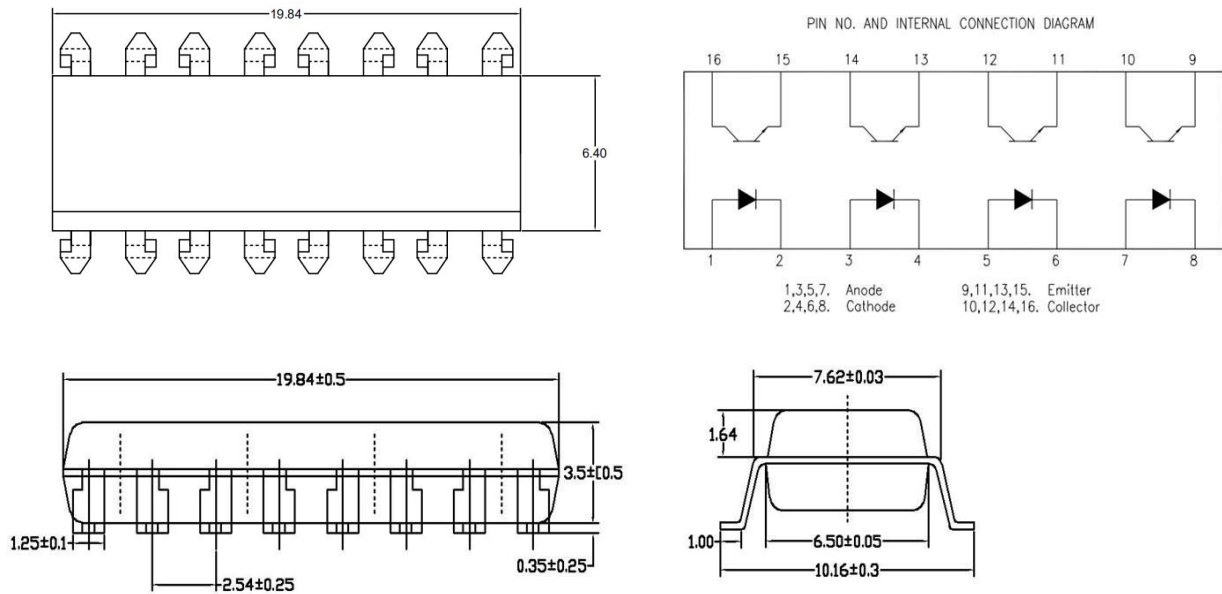

11. RECOMMENDED FOOT PRINT PATTERNS (MOUNT PAD)

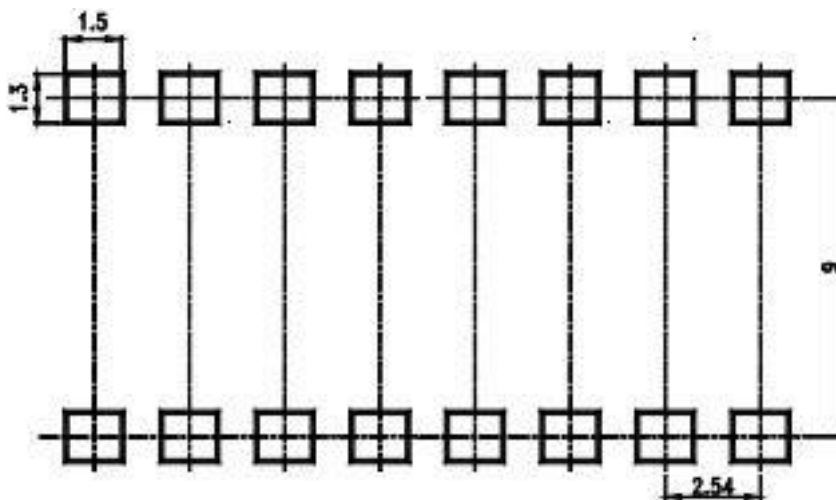

Unit : mm



## 12. Package Dimension

### (1) package dimension

DIP Type

Packing Information	
Packing type	Tube
Qty per Tube	24pcs
Small box (Inner) Dimension	525*128*60mm
Large box (Outer) Dimension	545*290*335mm
The Amount per Inner Box	1,200pcs
The Amount per Outer Box	12,000pcs

SOP Type

Packing Information	
Packing type	Tube
Qty per Tube	24pcs
Small box (Inner) Dimension	525*128*60mm
Large box (Outer) Dimension	545*290*335mm
The Amount per Inner Box	1,000pcs
The Amount per Outer Box	10,000pcs

### (2)Packing Label Sample

	  
Material Code : 120PCXXXXXX  P/N : OR-XXXXXX  Lot No. : XXXXXX-XXXXX-TX-X  D/C : XXXX  Qty : XXXX PCS 	<div style="display: flex; justify-content: space-around; align-items: center;"> <div style="border: 1px solid black; padding: 10px; text-align: center;">内箱码</div> <div style="border: 1px solid black; padding: 10px; text-align: center;">外箱码</div> </div> <p style="text-align: center;">“XXXXXXXXXXXXXXXX” (一体机序列码)  <b>Made in China</b></p>

#### Note:

1. Material Code :Product ID.
2. P/N :Contents with "Order Information" in the specification.
3. Lot No. :Product data.
4. D/C :Product weeks.
5. Quantity :Packaging quantity.

## 13. Reliability Test

NO.	ITEMS	Reliability Testing				
		QTY. (Pcs)	Condition	Process	Device	Standard
1	RSH 耐焊接热	22	260±5℃	10s/3 次	锡炉	JESD22-A106
2	HTSL 高温存储	77	125℃	168 hrs	高温烤箱 测试仪	JESD22-A103
				500 hrs		
				1000 hrs		
3	LTSL 低温存储	77	-55℃	168 hrs	低温箱 测试仪	JESD22-A119
				500 hrs		
				1000 hrs		
4	TC 温度循环	77	H:125℃ 15min ∫ 5min L:-55℃ 15min	300 cycle	冷热冲击机	JESD22-A104
5	TS 温度冲击	77	H:100℃ 5min ∫ 15s L:-40℃ 5min	300 cycle	冷热冲击机	JESD22-A106
6	HTOL 高温操作	77	110℃ IF=10mA Vce=5V	168 hrs	高温烤箱 测试仪、老 化电路板	JESD22-A108
				500 hrs		
				1000 hrs		
7	ESD-HBM 人体模式	22	≥8KV 1Cycle	1次	ESD静电测 试仪	JESD22-A114
8	SD 可焊性	22	Pb-free 245±5℃	5S/1次	锡炉	JESD22-B102
9	HTRB 高温反向偏压	77	HTRB @125℃ Vce=80v	168 hrs	高温烤箱 , 测试仪	JESD22-A103
				500 hrs		
				1000 hrs		
10	H3TRB 温湿度反向偏 压, 寿命试验	77	H3TRB 85℃,85%RH Vce=80v	168 hrs	恒温恒湿 机, 测试仪	JESD22-A101
				500 hrs		
				1000 hrs		
11	Autoclave 压力锅	77	Ta=121 ℃,100%RH,2atm	96hrs	压力锅	JESD22-A102

### 14. Temperature Profile Of Soldering

(1) IR Reflow soldering (JEDEC-STD-020C compliant)

One time soldering reflow is recommended within the condition of temperature and time profile shown below.  
Do not solder more than three times

Profile item	Conditions
Preheat	
- Temperature Min (T Smin )	150°C
- Temperature Max (T Smax )	200°C
- Time (min to max) (ts)	90±30 sec
Soldering zone	
- Temperature (TL )	217°C
- Time (t L )	60 sec
Peak Temperature	260°C
Peak Temperature time	20 sec
Ramp-up rate	3°C / sec max.
Ramp-down rate from peak temperature	3~6°C / sec
Reflow times	≤3

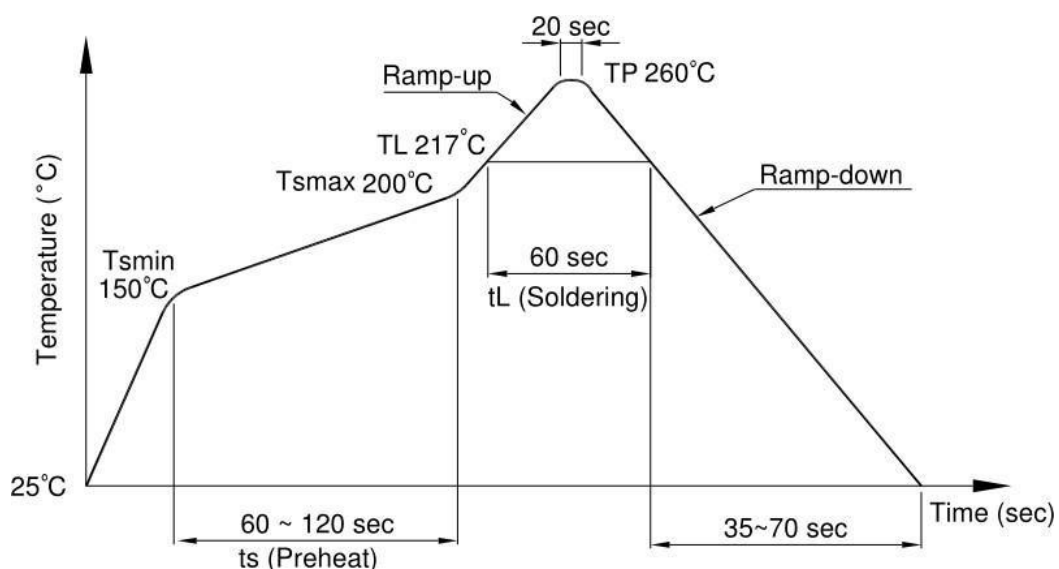

(2) Wave soldering (JEDEC22A111 compliant)

One time soldering is recommended within the condition of temperature.

Temperature	260+0/-5°C
Time	10 sec
Preheat temperature	5 to 140°C
Preheat time	30 to 80 sec

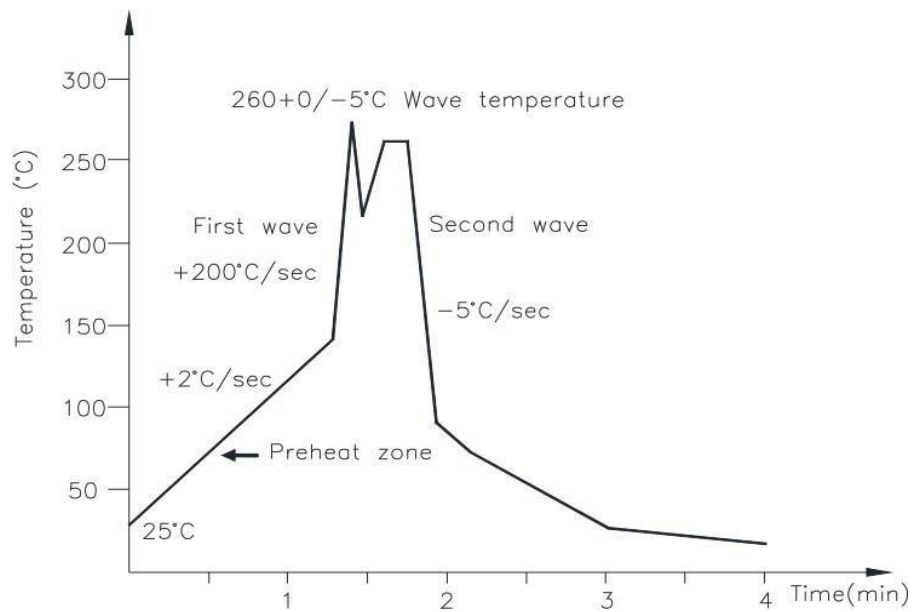

(3) Hand soldering by soldering iron

Allow single lead soldering in every single process. One time soldering is recommended.

Temperature	380+0/-5°C
Time	3 sec max

### 15. Characteristics Curves

Fig.1 Forward current vs Ambient temperature

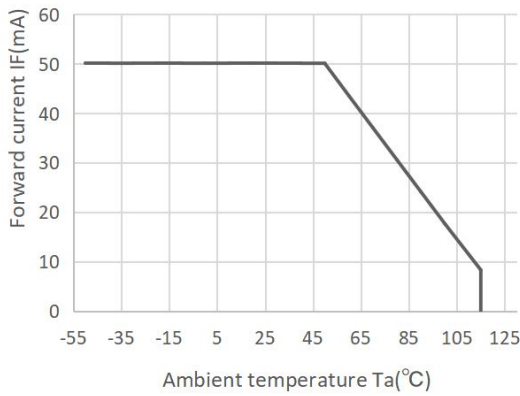

Fig.2 Collector Power Dissipation vs. Ambient temperature

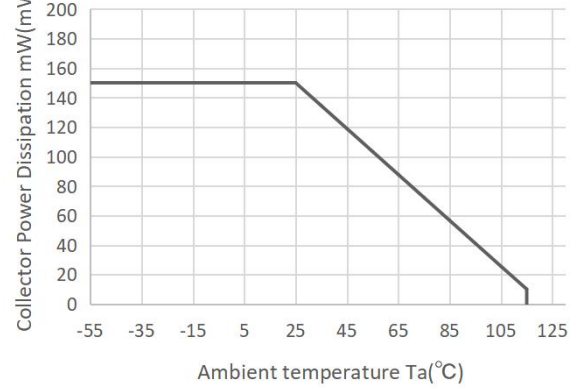

Fig.3 Collector-emitter Saturation Voltage vs. Forward Current

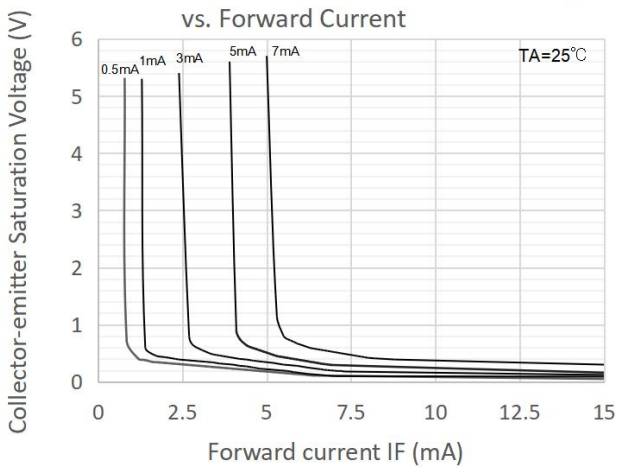

Fig.4 Forward Current vs. Forward Voltage

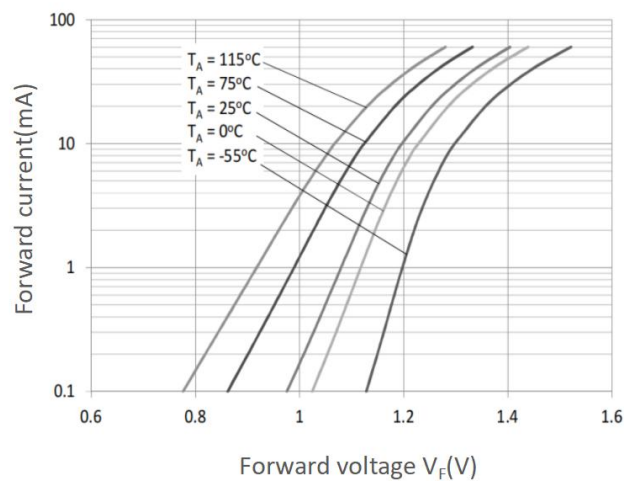

Fig.5 Forward Current vs. Current Transfer Ratio

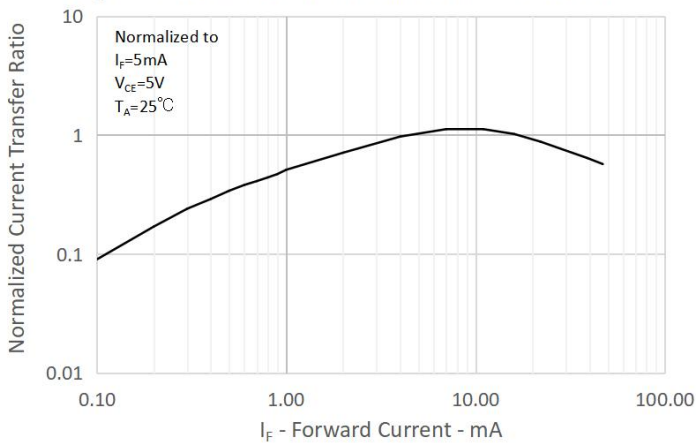

Fig.6 Collector Current vs. Collector-emitter Voltage

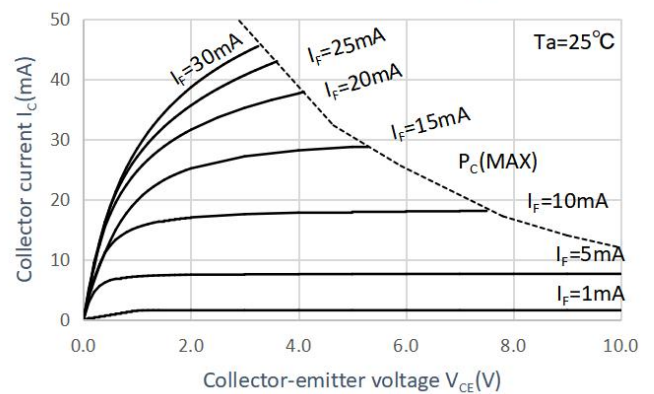

Fig.7 Relative Current Transfer Ratio vs. Ambient Temperature

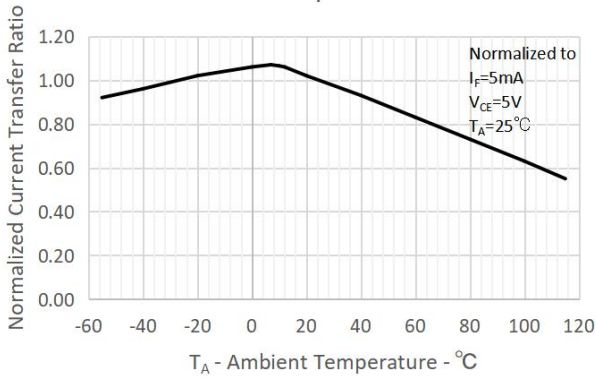

Fig.8 Collector-emitter Saturation Voltage vs. Ambient Temperature

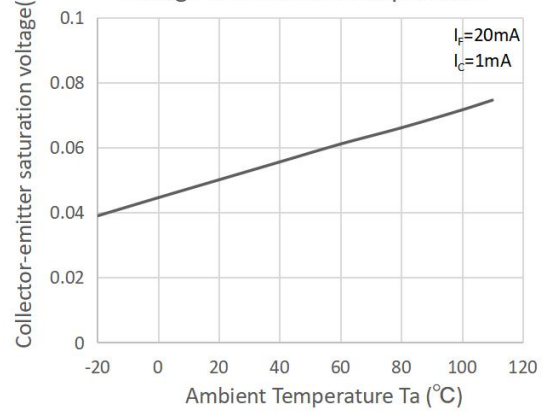

Fig.9 Collector Dark Current vs. Ambient Temperature

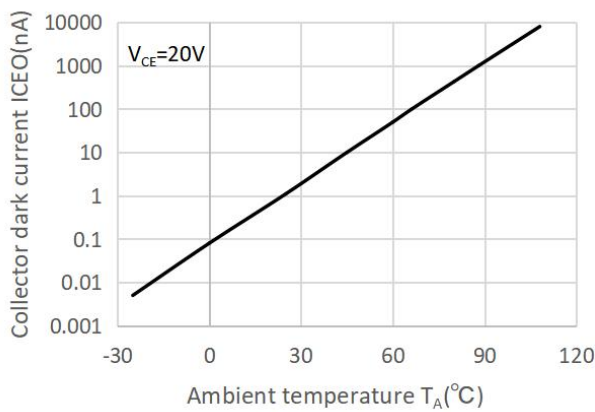

Fig.10 Respinse Time vs. Load Resistance

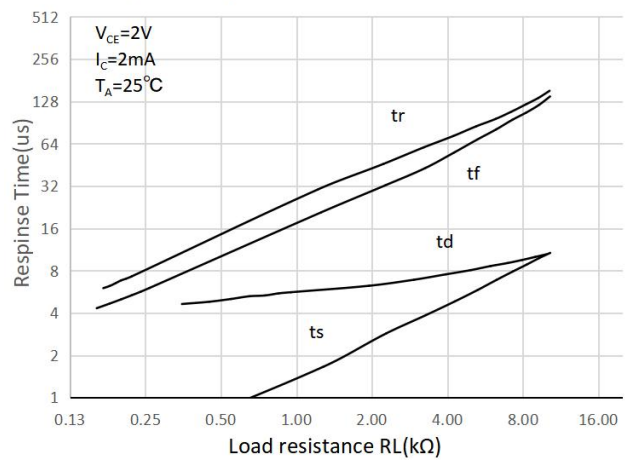
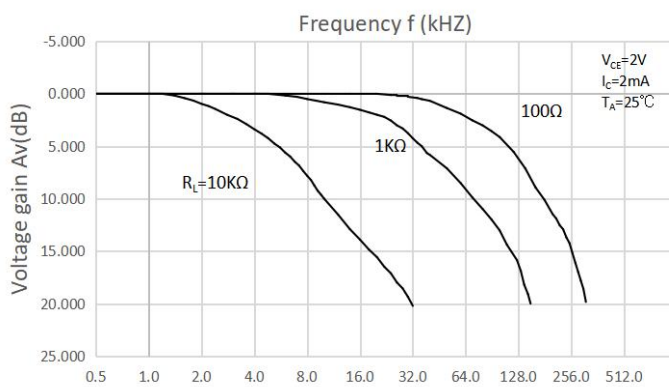
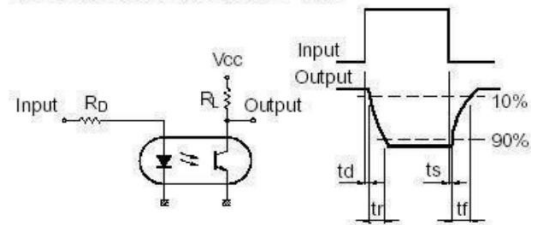

Fig.11 Frequency Response



Test Circuit for Response Time



Test Circuit for Frequency Response

